

SEG-9SP3 SECURITY GRILLE – SUPPLY OR RETURN

Complies with NIC recommendations and California BoP Title 24

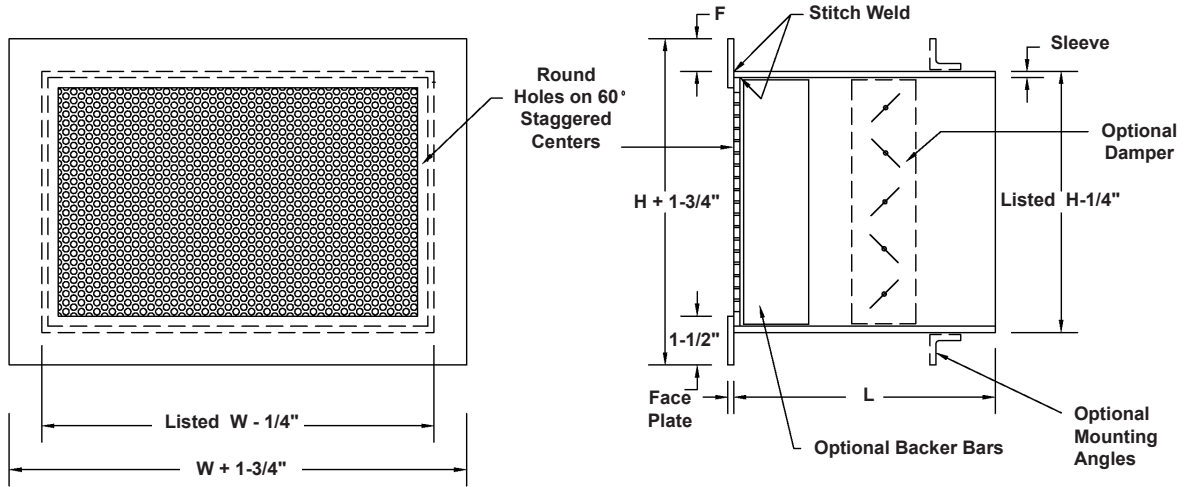

STANDARD CONSTRUCTION

Flange: 3/16" steel stitch welded to sleeve. 1" face flange.
Face: 3/16 thick steel stitch welded to sleeve. 3/16" diameter holes on 9/32" staggered centers.
Sleeve: 3/16" steel with continuously welded or formed seams.
Finish: Two part polyurethane inside and out. White.

REQUIRED CONSTRUCTION:

- Flange Material:** 3/16" steel (Std.)
 10 ga. steel
 12 ga. steel
 Other _____
- Face:** .187" thick with 3/16" dia. holes on 9/32" centers. (Std.)
 Other _____
- Flange "F":** 1" (Std.)
 Other _____
- Sleeve Material:** 3/16" steel (Std.)
 10 ga. steel
 12 ga. steel
 Other _____
- Finish:** White (Std.)
 Other _____
- Other Material:** **SEG-9SP3A** all aluminum (Consult factory for material thickness)
 SEG-9SP3SS all stainless steel (Consult factory for material thickness)

Sizes 18" x 18" and under may be constructed with a one piece face. See drawing No. SEG-9SP31

MOUNTING OPTIONS:

- 11A.** Two loose pieces of 1" x 1" x 3/16" mill finish steel angle loose for field welding to sleeve. Length equal to longest side of grille. Other angle size _____
- 11B.** Rear angle frame of 1" x 1" x 3/16" mill finish steel completely assembled for field welding to sleeve. Other angle size _____
- 12A.** Rear angle frame for bolting to sleeve. 1" x 1" x 3/16" steel with bolt holes 8" o.c. for 1/4" dia. bolts. No holes in sleeve. No bolts, nuts or washers. Other angle size _____
- 12B.** Same as **12A** with addition of bolt holes in sleeve. (Advise wall or ceiling thickness). Other angle size _____
- 23.** Masonry anchors: 1/2" x 3" Anchors 16" o.c., one per side minimum, welded to sleeve exterior. Other size or spacing _____
- 24.** Countersunk screw holes in face 10" o.c. with #10-24 x 2" long Torx security machine screws for 1-1/2" maximum ceiling thickness. 1" x 1" x 1/8" steel angle frame with matching holes and foldover nuts. Requires 1-1/2" flange.
- 25.** Countersunk screw holes in face 10" o.c. with #10 x 1-1/2" long Torx security sheet metal screws. Other screw length _____

ACCESSORIES:

- 16F.** Face operated opposed blade damper tack welded into sleeve. Dampers are adjusted using flat bladed screwdriver.
- 16R.** Rear operated opposed blade damper tack welded into sleeve. Dampers are adjusted using flat bladed screwdriver.
- 21.** 2" x 1/4" A-36 mild steel vertical backer bars 6" o.c.. Welded to sleeve tight to face.
- Other:** _____

Qty.	Listed Size		Sleeve O.D.		Masonry Opening		Sleeve Length L	Wall / Ceiling Thickness	Accessories	Mounting Option	Tag
	W	H	W	H	W	H					

To maintain KEESS' policy of continuous product improvement, we reserve the right to change prices, specifications, ratings or dimensions without notice or obligation.

Project		Location				
Architect / Engineer			CAPE COD SYSTEMS CORPORATION TEL. 1-888-227-8555			
Contractor						
Representative						
	Dwg. No.	SEG-9SP3w 7/10/2012				
	Date					