

Installation Instructions

700/700W/G-700/G2-700 Wall Guard

FIG. 1

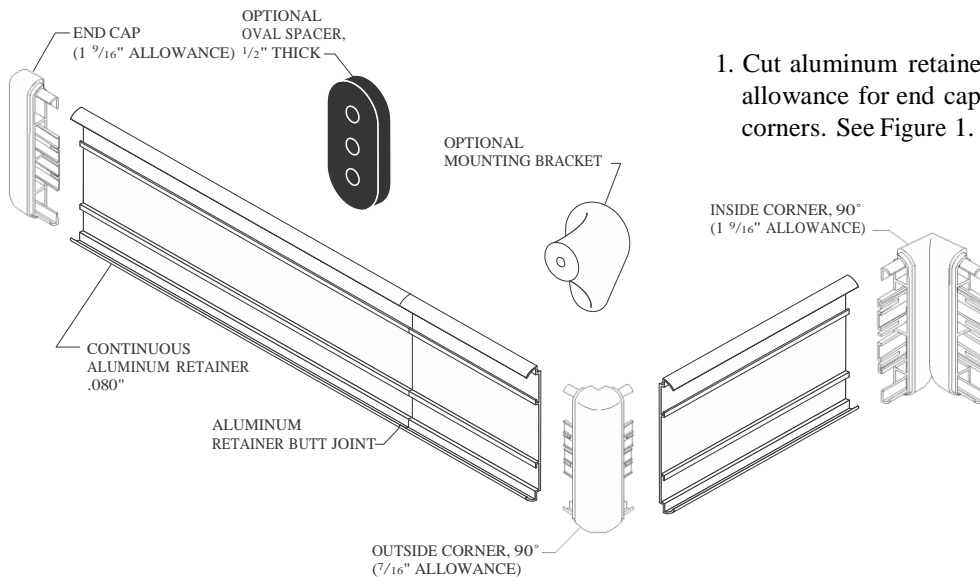

Please read all instructions before installing wall guard.

1. Cut aluminum retainer to desired length, leaving allowance for end caps, inside corners and outside corners. See Figure 1.

FIG. 2

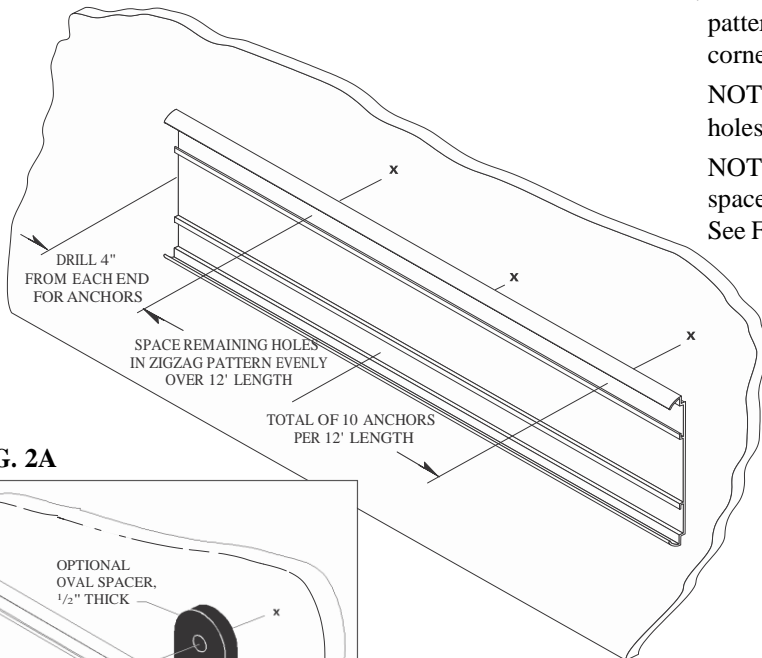

2. Drill holes in retainer using 1/4" drill bit in a zigzag pattern. Position retainer on wall allowing for end caps/corners. Level and mark holes. See Figure 2.

NOTE: For concrete or brick wall installation, drill 1/4" holes, 3/8" from each end of retainer for end caps/corners.

NOTE: If using brackets or rubber spacers, use bracket or spacer as a template to mark holes when drilling retainer. See Figures 2a & 2b.

FIG. 2A

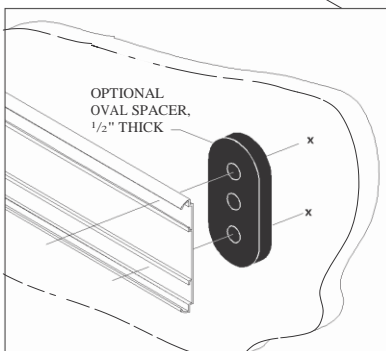
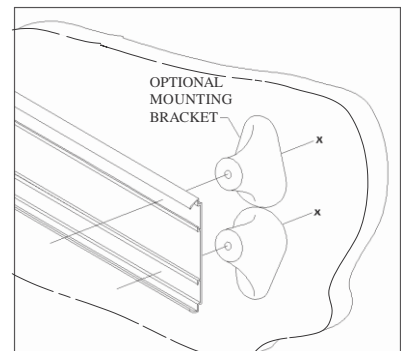

FIG. 2B



Installation Instructions

700/700W/G-700/G2-700 Wall Guard

FIG. 3

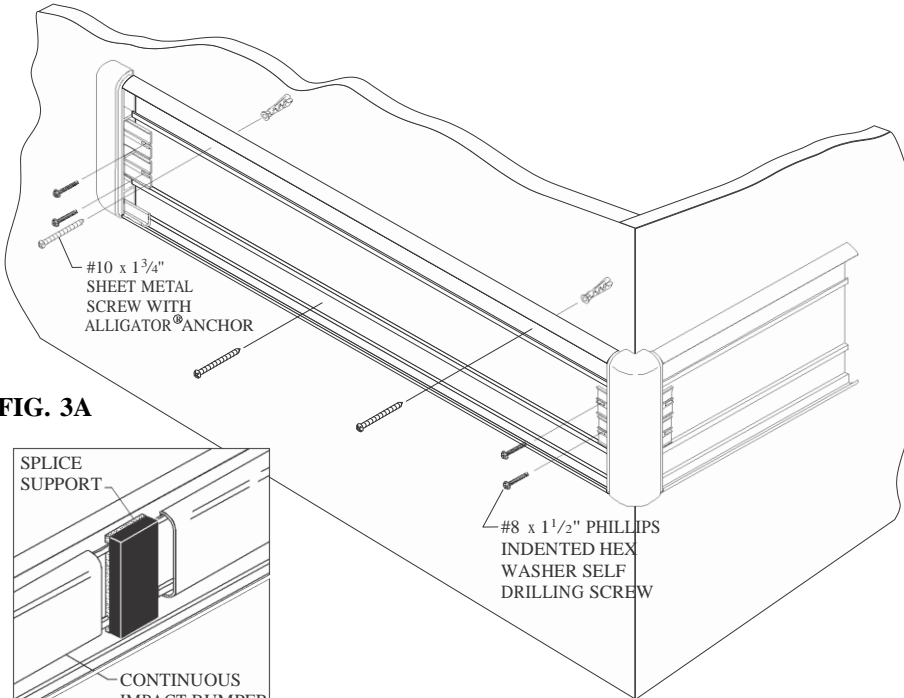

FIG. 3A

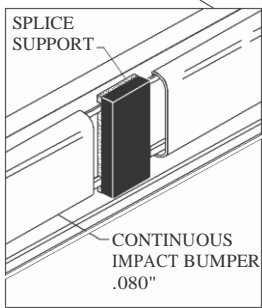
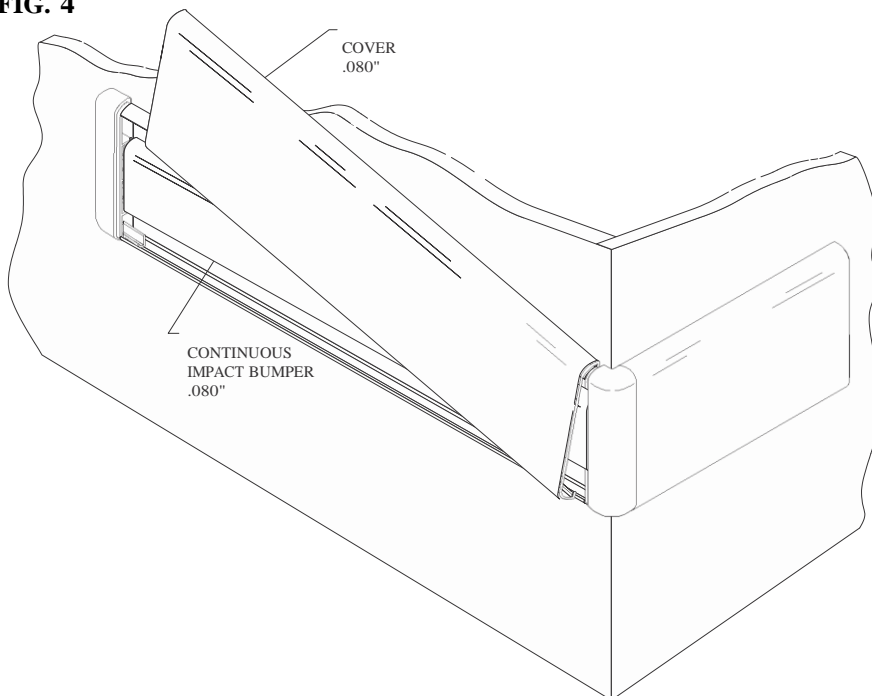

FIG. 4



3. Drill marked holes on wall using a 1/4" drill bit and position Alligator anchors into holes. Mount retainer on wall and tighten screws to secure. Slide end caps and corners onto the retainer and secure, leaving a 1/16" gap between returns/corners and retainer to allow for adjustment. See Figure 3.

With lengths over 12', a rubber splice is recommended between butt joints for added support. Remove the release paper from the back and press slice in place. See Figure 3a.

NOTE: For concrete or brick wall installation, use #10 x 1 3/4" Phillips pan head screws to secure end caps and corners.

NOTE: If rubber spacers are used, attach them behind the retainer at all mounting hole locations, including those for end caps and corners.

NOTE: If brackets are used, use a 3/4" drill bit for toggle wings or a 1/2" drill bit for lead anchors to drill the marked holes on the wall. Attach end caps and corners with 5/8" hex bolt assembly inserted from the back.

4. Cut the impact bumper to the length between the inside edge of the end caps/corners/splices. Position and snap bumper in place. Cut the cover to length between end caps and/or corners. (Note: Trim factory edges square before installation). Position cover on retainer and adjust returns and/or corners for a tight fit. Push cover over the retainer until it snaps into place. See Figure 4.